

8-port Ethernet Over SDH Mapping Device

www.data **OVERVIEW**

The CP1158 is one of the OPTRANS series chips designed by Chiphomer Technology Limited. It is a highly integrated EOS device that provides for mapping of 10/100/1000 Mbit/s Ethernet into SDH STM-1 Transport payloads. The device supports connection for up to eight 10/100 Mbit/s Ethernet ports, using SMII or SS-SMII interface, or one 1000 Mbit/s Ethernet port, using GMII interface. Ethernet frames are encapsulated using either GFP or HDLC-like protocol. The encapsulated Ethernet frames are then mapped into virtually concatenated VC-12, VC-3 or VC-4 payloads. Link Capacity Adjustment Scheme (LCAS) for VC-12/VC-3/VC-4 virtual concatenation is provided to enable hitless addition and removal of bandwidth under the control of a network management system. The VC-12, VC-3 and VC-4 POH generation and termination are performed. A byte-wide 19.44MHz Telecom Bus interface is provided for the SDH interface.

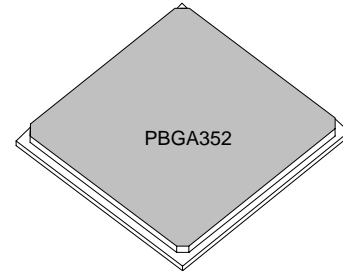

PBGA352
-40 ~ 85 °C

FEATURES

- Supports up to eight ports of full-duplex 10/100 Mbit/s Ethernet or a single port of full-duplex 1000 Mbit/s Ethernet with standards-compliant flow control supported:
 - 10/100 Mbit/s Ethernet interface supports SMII and SS-SMII
 - 1000 Mbit/s Ethernet interface supports GMII

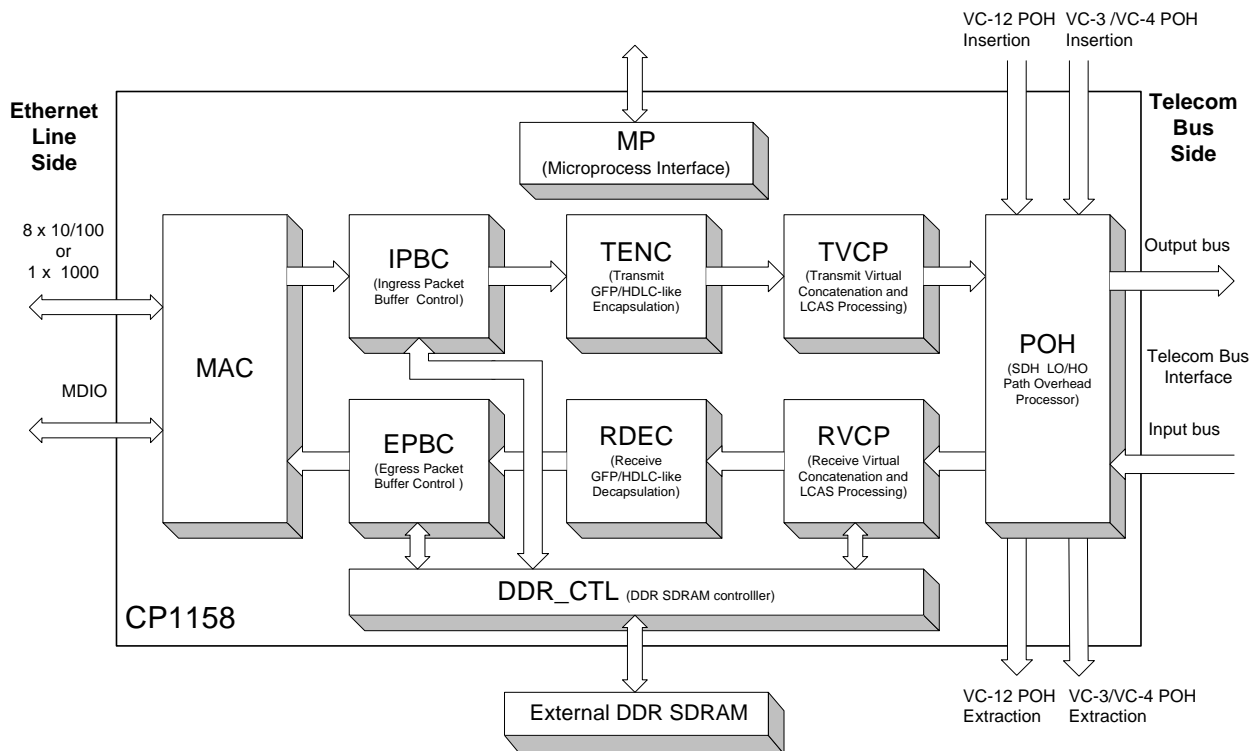

8-port Ethernet Over SDH Mapping Device

- Ethernet Management interface (MDIO) for control and configuration of external connected PHYs
- Provides IEEE 802.3 Management Statistics (RMON)
- Supports multiple virtual concatenation groups from one Ethernet port based on VLAN tag identification
- Supports multiple virtual concatenation groups to one Ethernet port based on the user's configuration
- Supports up to 16 virtual concatenation groups
- Supports up to four priority queues, enabling time-sensitive data to have access to the network with minimal delay
- Provides RED algorithm for buffer management
- Provides per-priority scheduling using Round Robin mechanism
- Supports the following encapsulation/decapsulation protocols on a per port basis:
 - ITU-T G.7041, Generic Framing Procedure (GFP)
 - HDLC-like Framing, including the following protocols:
 - ◆ ITU-T X.86/X.85, Link Access Procedure SDH (LAPS)
 - ◆ RFC1662, Point-to-Point Protocol (PPP)
 - ◆ RFC3518, PPP Bridging Control Protocol (BCP)
- Supports the following SDH mapping formats:
 - C-12/VC-12/TU-12/TUG-2/TUG-3/VC-4/AU-4/STM-1
 - C-3/VC-3/TU-3/TUG-3/VC-4/AU-4/STM-1
 - C-4/VC-4/AU-4/STM-1
- Supports selection of VC-4, VC-3 or VC-12 virtual concatenation on a per virtual concatenation group basis
- Supports hitless Link Capacity Adjustment Scheme (LCAS) (ITU-T G.7042)
- Supports up to 240ms (VC-12)/254ms (VC-3) of differential delay compensation
- Supports TU-12/TU-3 pointer interpretation
- Supports VC-12, VC-3 and VC-4 POH generation and termination
- Full access VC-12, VC-3 and VC-4 POH through external serial interface
- Provides byte-wide 19.44MHz Telecom Bus interface
- Controlled High-Z output on Output Telecom Bus
- Provides three bus timing modes for Output Telecom Bus
- Supports per-port Ethernet side and SDH system side loopbacks for system level diagnostics
- Provides 16-bit Intel/Motorola microprocessor interface
- Provides an IEEE 1149.1 compliant JTAG test port for boundary scan
- Operating Industrial temperature range: -40°C ~ 85°C
- Low power 1.8V core with 3.3V LVTTTL I/O, LVPECL I/O and 2.5V SSTL_2 digital I/O
- The maximum power consumption is 2.3W
- 27x27mm PBGA 352 package

APPLICATIONS

- SDH Add/Drop Multiplexers
- Multi-service Access Platform (MSAP)
- Test Equipment
- SDH Terminal Multiplexers
- Customer Premises Equipment (CPE) platform

8-port Ethernet Over SDH Mapping Device

TYPICAL APPLICATION

www.dataSheet4U

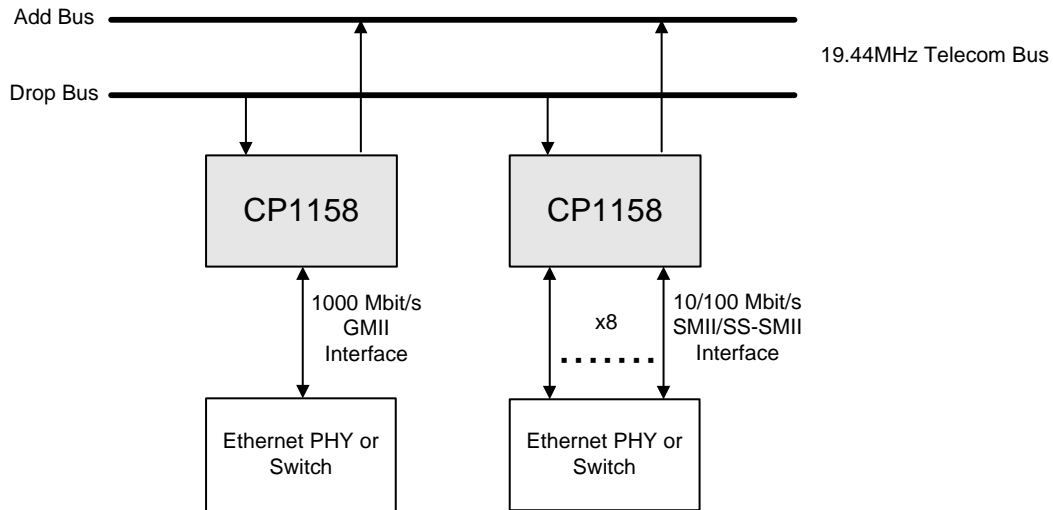

RELATED PRODUCTS

- CP1154: 4-port Ethernet over SDH Mapping device
- CP1122A: STM-1 Single Chip Add/Drop Multiplexer System device
- CP1121A: STM-1/4 Single Chip Add/Drop Multiplexer System device
- CP1181: 21 Channel Dual Bus E1/T1 Mapper
- CP1130: SDH/SONET 155/622 Bus Converter and Aggregator
- CP1125: Dual 622/155 SDH/SONET Framer with LOPP and Cross Connect